

## Industrial Panel PC with 10" Flat-panel Display "4-slot Passive Backplane and 70 W Power Supply"



The IWS-513 is an ultra compact unit able to fit into any application with space limitations. The IWS-513's heavy-duty plastic front panel meets NEMA 4/12 and protects the system against corrosive substances, moisture and dust.

The station's ability to easily withstand shock, vibration and high temperatures makes it well suited for applications involving harsh industrial environments.

Two types of sealed membrane keypad assemblies are available to mount separate from the IWS-513.

The station can optionally be equipped with a touchscreen.

### Features

- Heavy-duty steel chassis and NEMA 4/12 plastic front panel
- Flat Panel options :  
9.4" Mono DD, 9.4" Mono EL, 10.4" SVGA DSTN or 10.4" SVGA TFT panel
- 4-slot ISA passive backplane
- Panelmount
- 70 W switching power supply, or optional +12, +24 or +48 V<sub>DC</sub> power supply
- PC/104 Flat Panel VGA controller
- Floppy disk behind dust proof door on side panel. Keyboard connector, on/off switch, CRT VGA connector and display control on rear panel
- 30 CFM cooling fan (flow-in) on rear panel with air filter
- Separate assembly with sealed-membrane keypad optional. 59 data-entry keys or 20 function keys
- 10" analog resistive touchscreen (optional except for 9.4 Mono DD version)

### DIMENSIONS

Units in mm

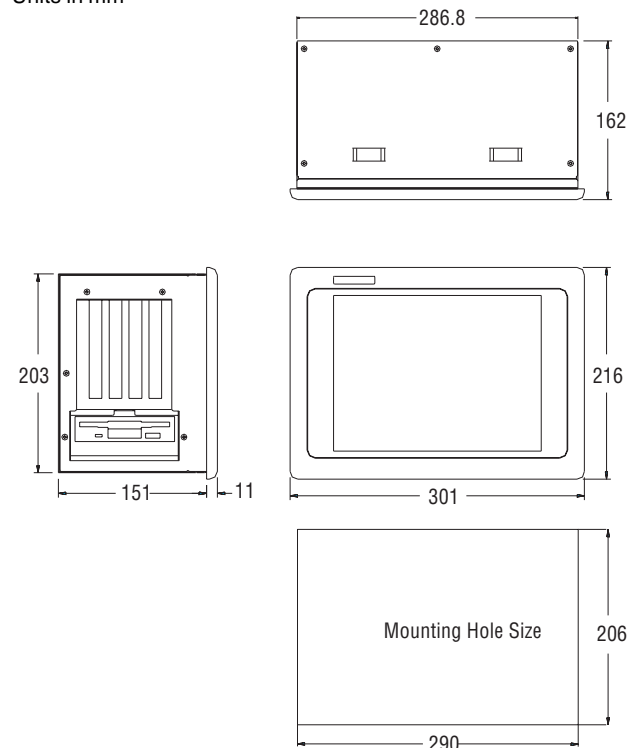

## Specifications

- **Construction** : heavy-duty NEMA 4/12 plastic front panel with coated steel chassis
- **Passive Backplane** : 4-slot ISA
- **Disk Drive Housing** : one 3½" FDD drive behind lockable dust proof door and one 3½" HDD drive
- **System Cooling** : one 30 CFM cooling fan (flow-in) on rear panel with air filter
- **Dimensions** : 301(W) x 216(H) x 151(D) mm
- **Weight** : 6 Kg

## FLAT PANEL DISPLAY

Flat Panel	Mono DD	Color DSTN	Color DSTN	Color TFT
Size/type	9.4" VGA	9.4" VGA	10.4" VGA	10.4" SVGA
Display area in mm.	192 (H) 144 (V)	192 (H) 144 (V)	211.2 (H) 158.4 (V)	211.2 (H) 158.4 (V)
Resolution	640 x 480	640 x 480	640 x 480	640 x 480
Colors	16 gray scales	4096	4096	262,144

## REAR PANEL

- **Connectors**: 5-pin DIN Keyboard connector and 15-pin D-type connector for external CRT display
- **Control** : power on/off, display brightness/contrast

## POWER SUPPLY

Power Supply	Input Voltage	Maximum Output Current			
		+5V	+12V	-5V	-12V
Universal 70 W	85~260V <sub>AC</sub>	7A	2.5A	0.3A	0.3A
+48V <sub>DC</sub> / 70 W	+36~+72V <sub>DC</sub>	7A	2.5A	0.3A	0.5A
+24V <sub>DC</sub> / 70 W	+19~+30V <sub>DC</sub>	7A	2.5A	0.3A	0.5A
+12V <sub>DC</sub> / 65 W	+8~+16V <sub>DC</sub>	6A	2A	0.3A	0.5A

## ENVIRONMENTAL

- **Operating Temperature** : 32 to 122°F (0 to 50°C)
- **Relative Humidity** : 5 to 95%, non-condensing
- **Altitude** : 10,000 feet or 3000 meters
- **Vibration** : 5~17 Hz, 0.1" double-amplitude displacement  
17~500 Hz, 1.5G peak-to-peak
- **Shock** : 10 G peak acceleration, 11 msec duration
- **Safety** : meets UL/CSA/TÜV
- **EMI** : meets FCC/VDE Class A

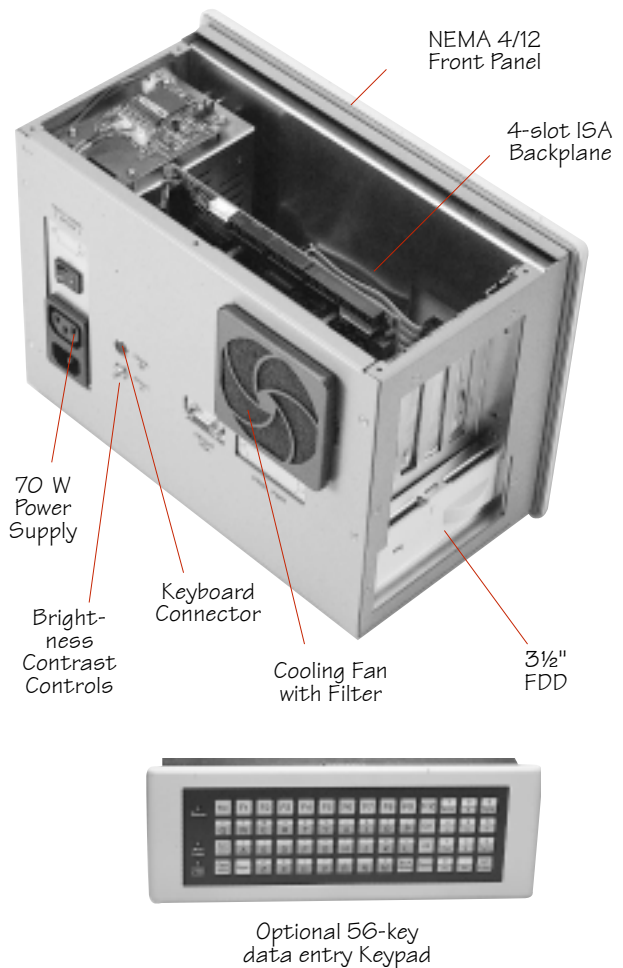

## Ordering

- ☐ **IWS-513TV** : Panel PC with 10.4" Color TFT VGA Display includes :  
ISA 4-slot passive backplane  
PC/104 VGA Card, 1 MB installed  
one 3½" FDD, 1.44 MB  
Universal 70 W power supply, 85~265 V<sub>AC</sub>
- ☐ **IWS-513DV** : Panel PC with 10.4" Color DSTN VGA Display includes : same as IWS-513M
- ☐ **IWS-513MV** : Panel PC with 9.4" Mono VGA DD Display includes : same as IWS-513TS
- ☐ **IKB-106** : Sealed Membrane Keyboard with 20 function keys
- ☐ **IKB-107** : Sealed Membrane Keyboard with 56 data-entry keys  
Optional Touchscreen